



#### **Molded SAN Clear Filter Housing - Jumbo Design**

GPS Jumbo Transparent Filter Housings are made of SAN material with innovative features like lower pressure drop at higher flow rate, larger connections, air venting provision, robust knife-edge, molded structure, zero bypass and leak proof sealing. They are sealed with top seated Buna-N/Silicon/Viton\* 'O' ring by positive tangential contact that eliminates accidental misplacement.

The larger body size allows for greater cartridge capacity, thus reducing the number of vessels normally required in parallel installation. The internal port has been enlarged from standard size to allow liquid to pass through with minimum restriction.

Housings are stress relieved for added clarity and strength. Transparent housings offer on-site examination of flow, cartridge performance and life.

Caps are manufactured of reinforced polypropylene and are available with 1" and 1.5" BSP (F) connections to match various flow rating and piping configurations. Caps are available with a pressure release mechanism to release the housing pressure when changing a cartridge. Pressure relief mechanism is constructed of stainless steel spring and screw and black polypropylene button.

All caps come with four mounting brackets for easy installation.

All housings have been tested and passed the hydrostatic leak and burst pressure to ensure consistence safe performance.

\*Viton is a registered **trademark** of Dupont.

#### **Features & Benefits:**

- Highly durable SAN material

- Lower Pressure Drop @ Higher Flow Rate
- Specially designed for higher flow rates.
- Ideal substitute for costly low pressure SS housings.
- An extra large cartridge results in higher dirt holding capacity.
- Molded Construction for Product Consistency
- Robust knife-edge design ensures consistent cartridge sealing
- Thicker Walls for Increased Strength
- Leak Proof Sealing
- Larger Connection for Maximum Output
- Air Release Mechanism
- Mounting Holes Provision

#### **Molded SAN Clear Filter Housing - Jumbo Design**

GPS Transparent housings are ideally suited for photographic, Vending machine, under sink residential water, food service and processing applications, laboratory use and as flow sight indicators.

#### **Molded SAN Clear Filter Housing - Jumbo Design**

##### **Materials of construction**

Sump: SAN (Styrene Acrylo-nitrile)  
 Head: Reinforced Polypropylene  
 Vent: Polypropylene with SS Spring and Screw  
 Seal: Silicon

##### **Configurations**

Inlet/Outlet connection: 1", 1.5"  
 Connection type: Threaded BSP (F)  
 Cartridge type: DOE  
 Vent: Provided

##### **Operating conditions**

Max. Operating Pressure: 7 kg/cm<sup>2</sup>  
 Max. Operating Temperature: 70<sup>0</sup>C

##### **Cartridge Capacity**

Single

##### **Cartridge dimensions accepted**

- i) 110 mm OD X 10"/254 mm
- ii) 110 mm OD X 20"/508 mm

##### **Cartridge configurations accepted**

Double Open End type

##### **Design Options**

Molded construction

#### **Molded SAN Clear Filter Housing - Jumbo Design**

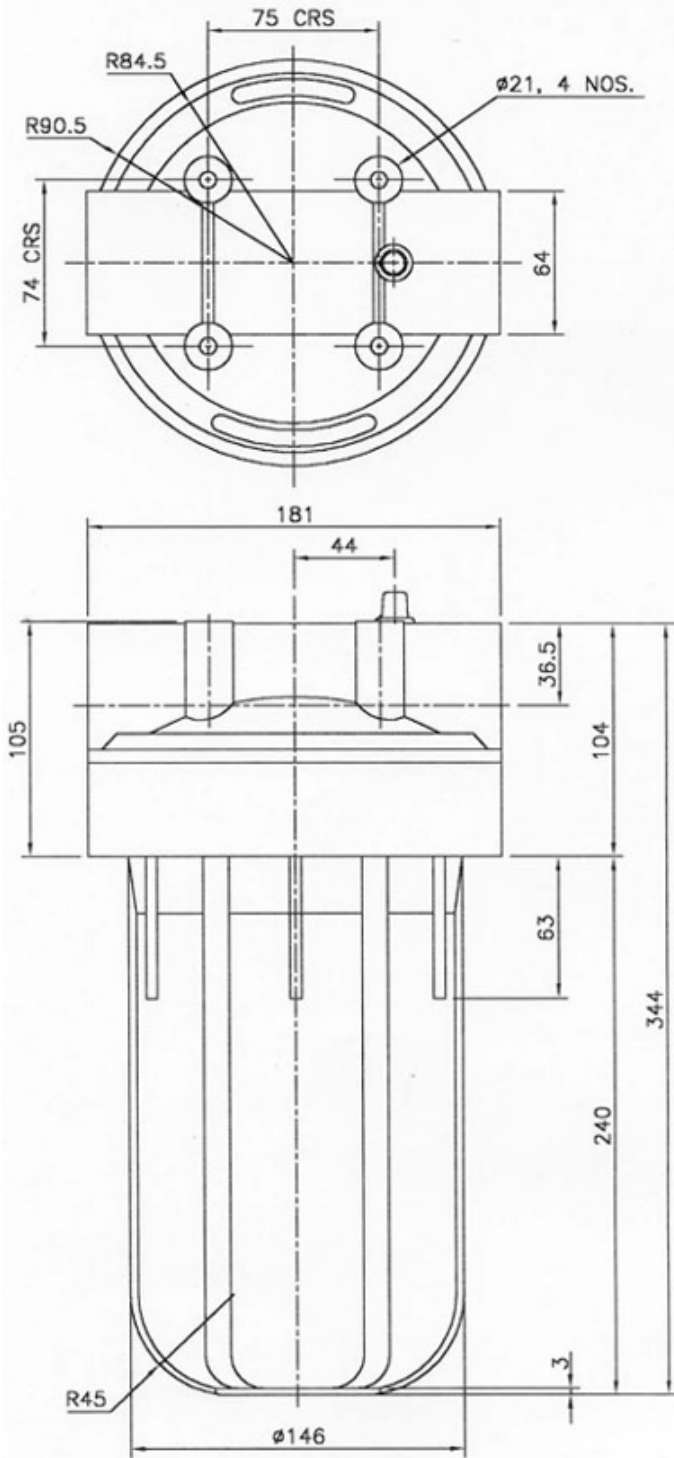

<b>GOPANI PRODUCT SYSTEMS</b>		
MODEL NO. : ,	WEIGHT :	QTY. : 1 NO.
DWG. NO. : ,	REF. NO. : ,	MAT./SIZE : ,
DRAWN :		
CHD. :		
APP. :		
REV. :	DATE : 21/01/2004	SCALE : 1 : 2.5

**Molded SAN Clear Filter Housing - Jumbo Design Request a Quote or More Information**

\*Name :

Company :

Title/Department :

\*Phone :

\*Email :

Address :

Country :

Comments :

Please have someone contact me.

Please send me a quote.

- I am interested in (please check one or more):
- Filter Housings for Liquid Filtration
  - Filter Housings for Air/Gas Filtration
  - Filter Media for Liquid Filtration
  - Filter Media for Air/Gas Filtration
  - Sintered Filter Media
  - Hydraulic Filters
  - Domestic Water Purifiers
  - Whole House Filtration Systems

How did you hear about us?